

ASH-HESS-15~40

15kWh 20kWh 25kWh 30kWh 35kWh 40kWh

Product Datasheet

Release date: 2023-09-20



Guangdong ASGOFT New Energy Co., LTD.

Add: No.9 Zhongxin Road, Dalang Street, Longhua District, Shenzhen, China

Powergo Energy GmbH

Add: Großer Schippsee 44, 21073 Hamburg, Germany

Email: asgoftservice@pairbest.com Website: www.pairbest.com

1. Battery Apparent Size

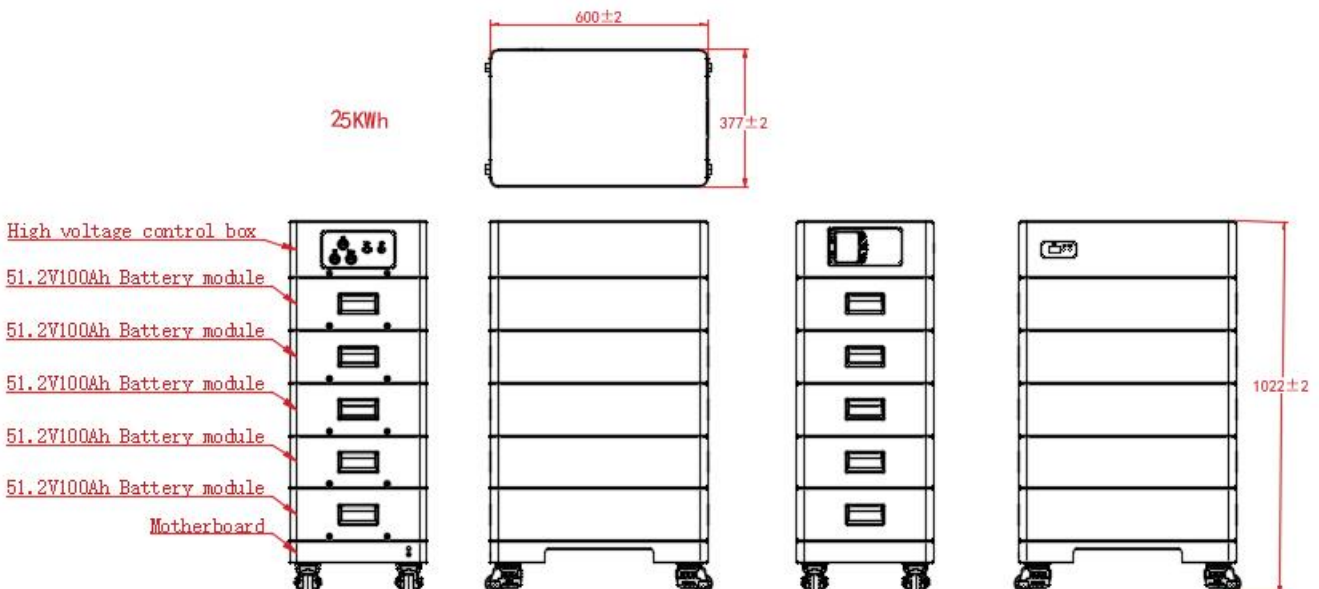
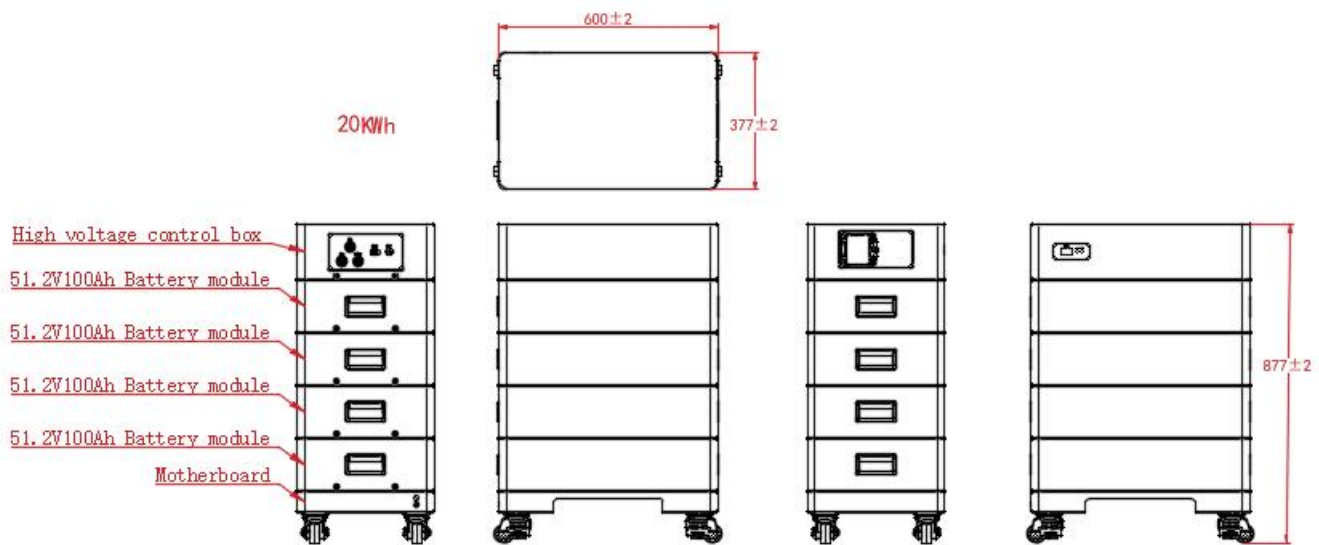
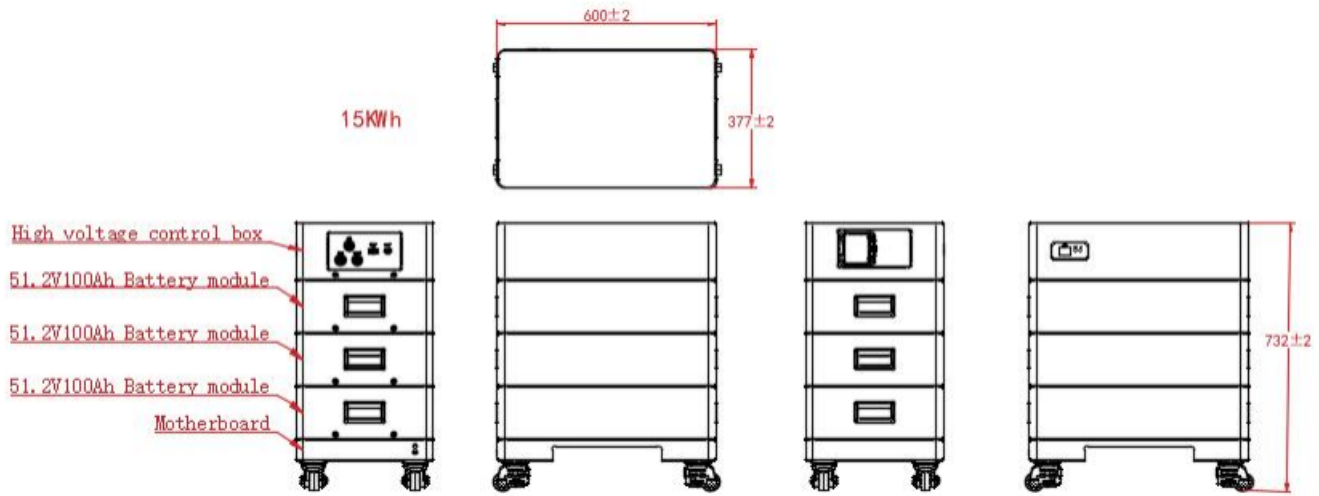

30KWh

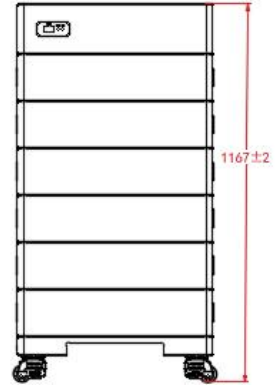
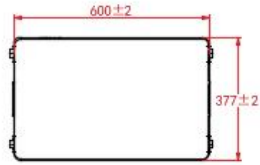
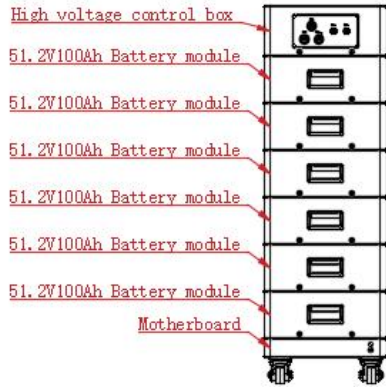

35KWh

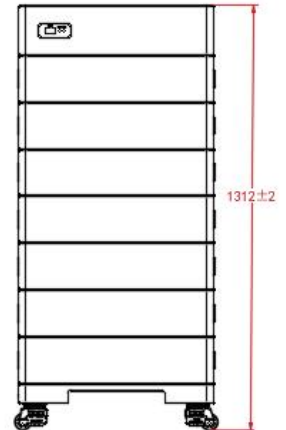
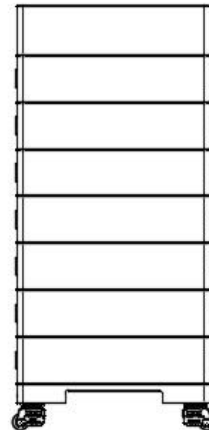
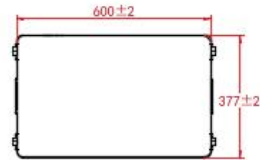
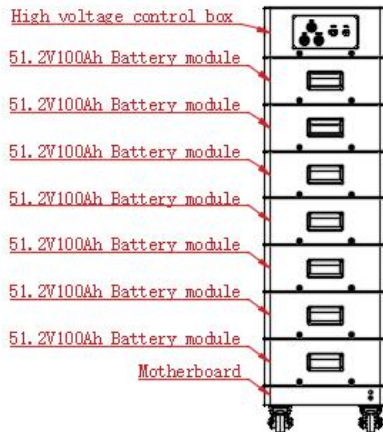

40KWh

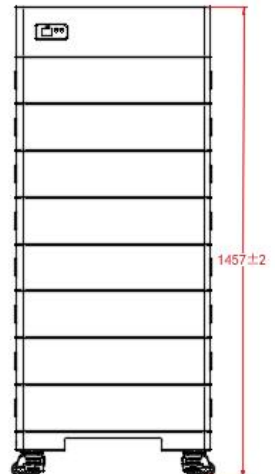
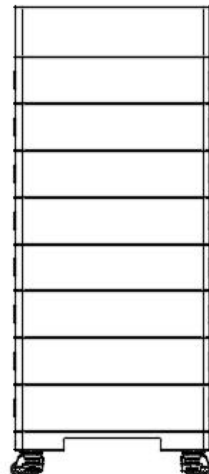
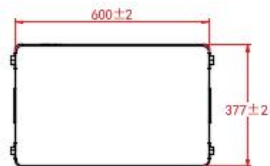
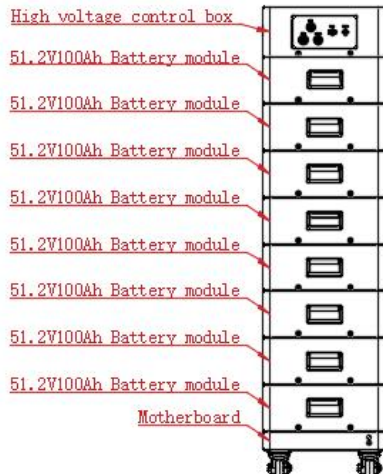

2. Battery Module Structure Size

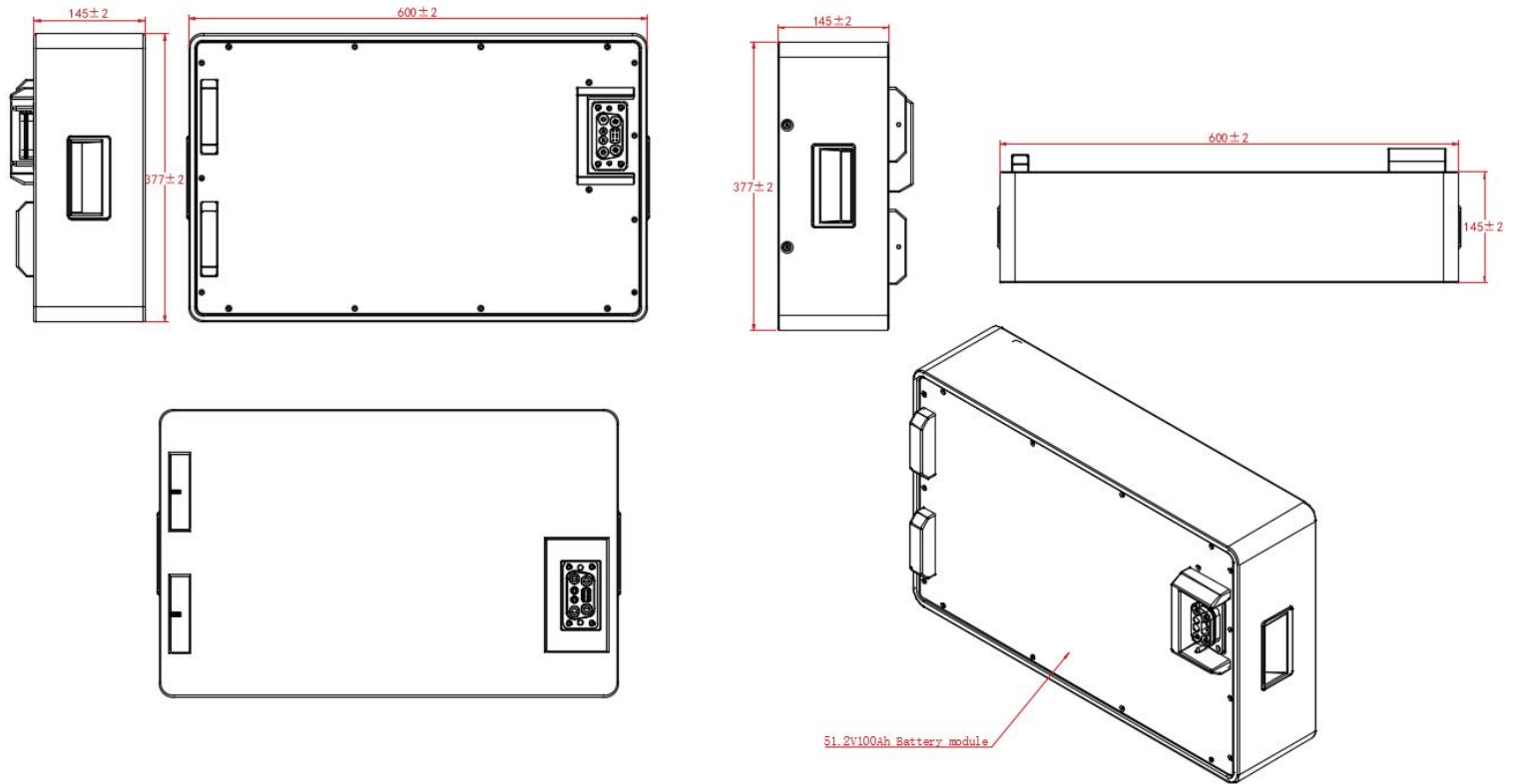

3. High Voltage Box Structure Size

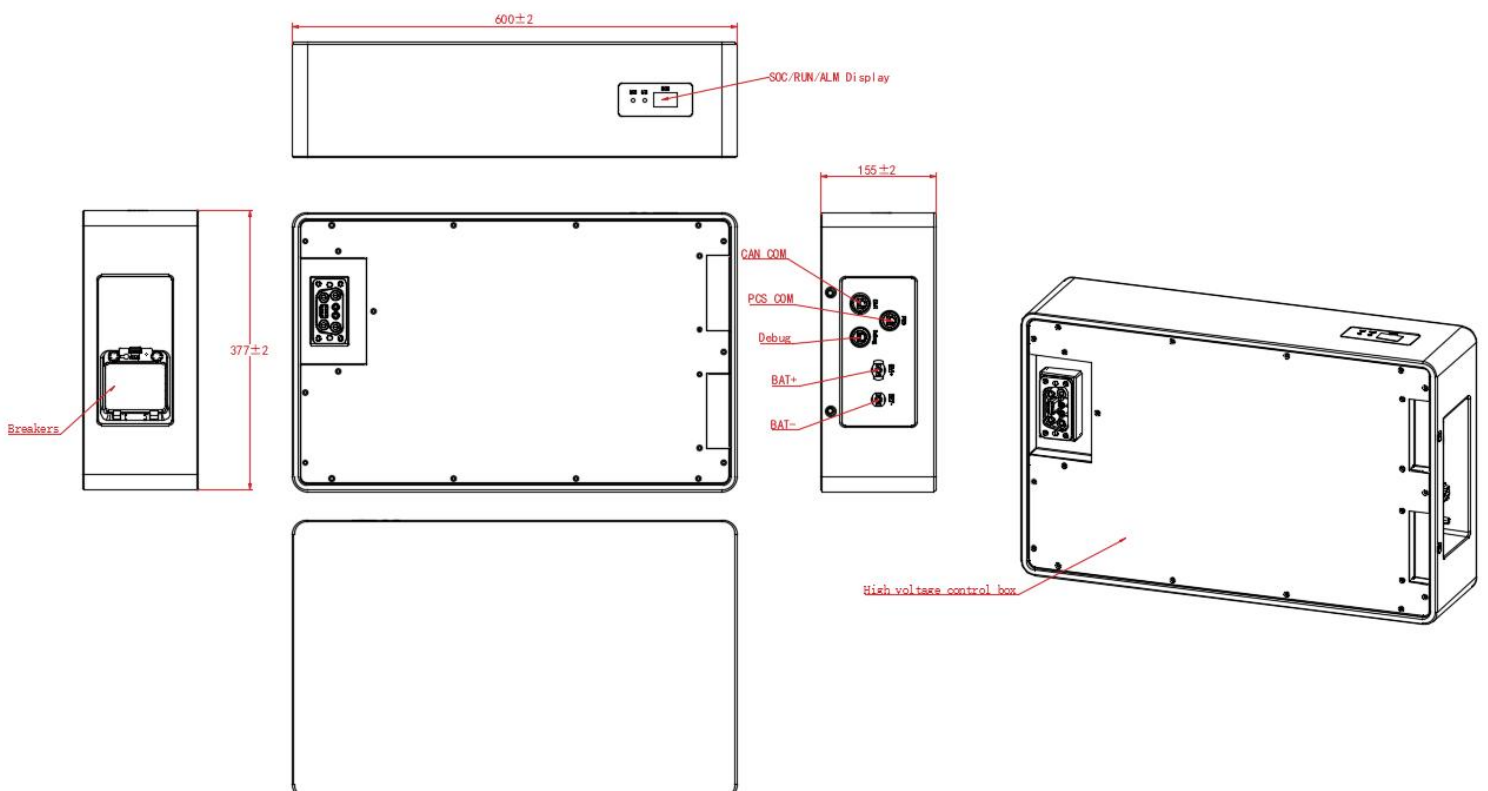

4. Model Numbers are As Below



5. Main Specifications

Item	ASH-HESS-15	ASH-HESS-20	ASH-HESS-25	ASH-HESS-30	ASH-HESS-35	ASH-HESS-40
Capacity	100Ah	Standard discharge after Standard charge				0.5CA
Layers	3	4	5	6	7	8
Discharge cut-off voltage	121V	161V	201V	241V	281V	321V
Charge cut-off voltage	175V	233V	291V	350V	408V	467V
Rated Voltage	153.6V	204.8V	256V	307.2V	358.4V	409.6V
Output Power	15kWh	20kWh	25kWh	30kWh	35kWh	40kWh
Max Charging Current	50A Ampere-meter, Maximum allowable charging current of the battery pack					
Max Discharging current	50A Maximum discharge current allowed by the battery pack					
Operation Temperature Range	Charge: 0~55 C		Discharge: -20~60 C			
Size(mm) L*W*H	600*377*732	600*377*877	600*377*1022	600*377*1167	600*377*1321	600*377*1457
Weight	170kg±5%	212kg±5%	255kg±5%	296kg±5%	338kg±5%	380kg±5%